



Brandstrom Instruments

Forward Thinking in Optical Shutter Technology



Agenda

- Brandstrom Instruments Overview
- Products
- Research and Development
- Company Statistics
- Organization Chart
- Facilities
- Expansion
- Manufacturing
- Manufacturing Equipment
- Lab and Test Capabilities
- Quality Systems
- Quality Products
- Custom Product Development
- COTS Rotary Solenoids
- COTS Shutters



Brandstrom Instruments Overview

- Brandstrom Instruments was founded in 1972 serving the aircraft industry with the design and manufacturing of warning indicators for cockpit panel instruments
- In March of 1975, Brandstrom Instruments, Inc. relocated to the present site in Ridgefield, CT
- Building on our strong brand and customer loyalty, Brandstrom Instruments has focused its efforts on the development of a line of highly reliable electro-optical shutters for thermal imaging and laser applications



Brandstrom Instruments Overview

- Our customer base includes tier one defense, aerospace and high technology companies that provide state of the art imaging products to the military, homeland security and commercial industrial markets
- Today Brandstrom Instruments is a preeminent industry manufacturer of robust precision optical shutters
- We see ourselves as the innovator in solenoid and optical shutter design, providing subsystem engineers with new levels of reliability in increasingly constrained envelope spaces and power specifications
- Our corporate headquarters and manufacturing facilities in Ridgefield CT are well equipped with extensive and continuously expanding production capacities for both short and long run requirements



Products

Latching 2-position and Self-restoring 2-position Rotary Solenoids

- Flag Indicators:

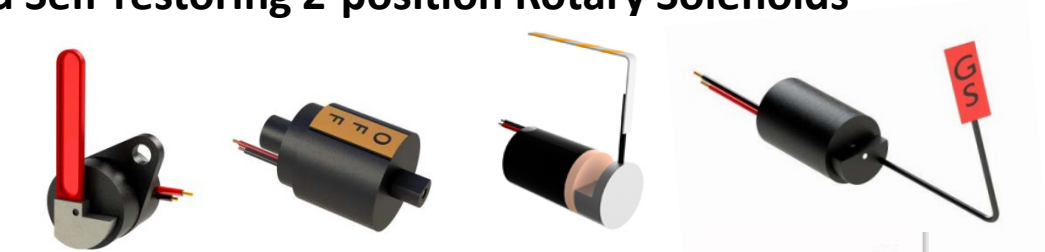

- Thermal imaging shutters:

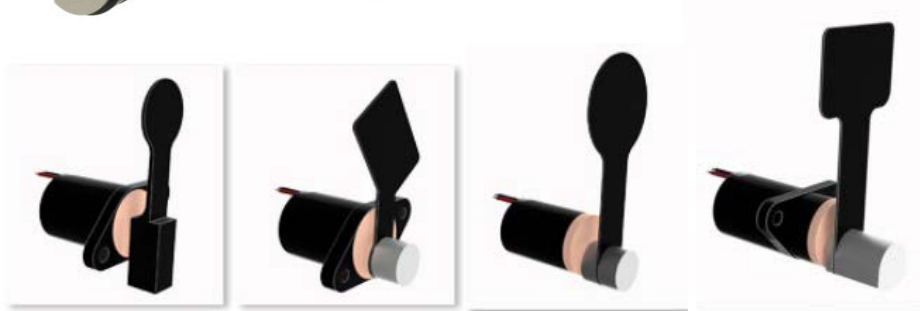

- Laser shutters:

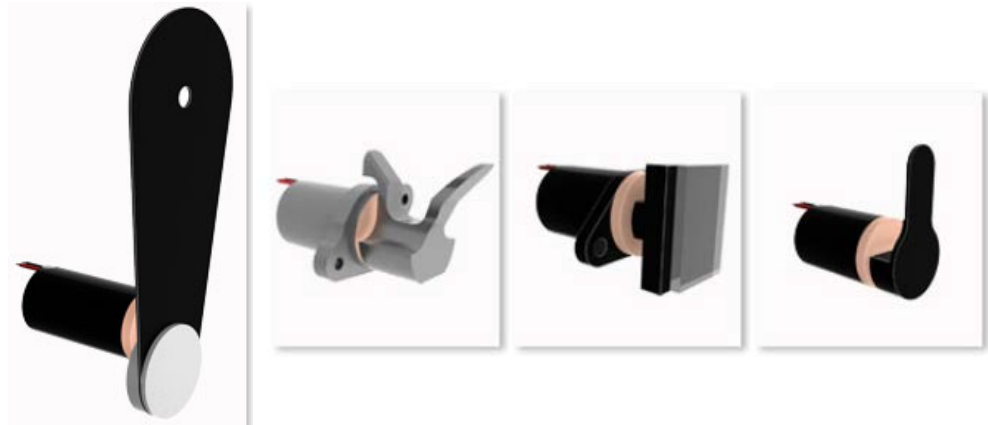



Products

- **Aerospace, dual band and fused image shutters:**

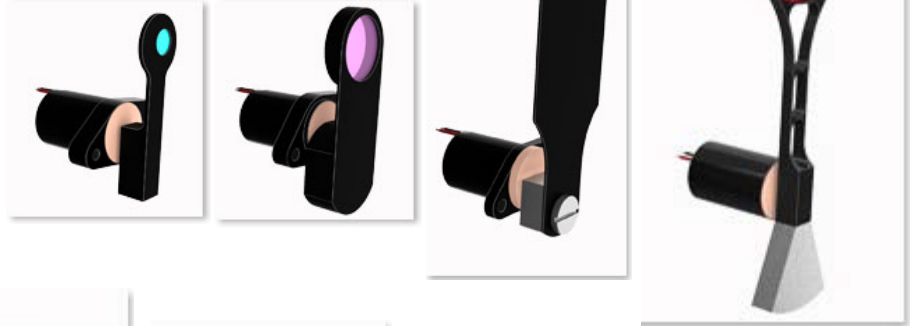

- **Medical, optical, and spectroscopy shutters:**

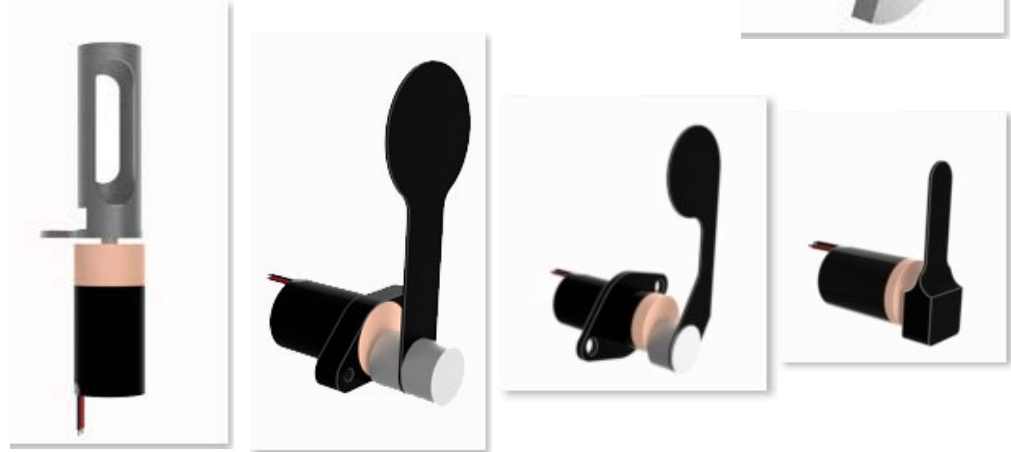

- Our innovative designs for high torque and lower power consumption and reputation unmatched quality and customer satisfaction have always been the key factors in the success of the company



Research and Development

- We are committed to ongoing R&D projects with the goal of continually advancing our technologies
- Our Current R&D projects include solenoid designs with:
 - Lower Power (mW)
 - Lighter Weight
 - Smaller Space
 - Lower Profile
 - Lower Noise
 - Higher Torque

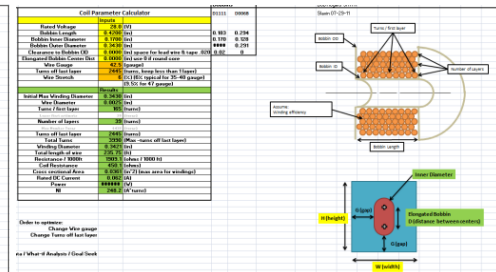
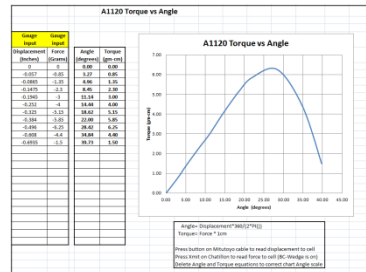
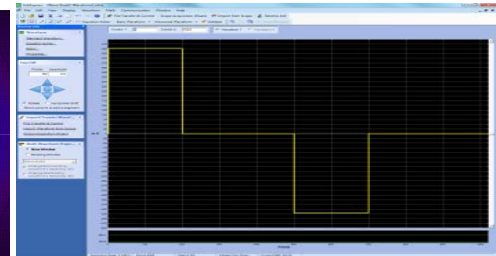
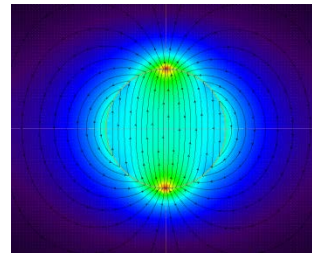



Company Statistics

- Facility Size:

We currently operate out of two buildings utilizing a total of just over 15,000 square feet

- Key Programs:

Volume programs involving Rapid “Ramp UP” with well over 250,000 shutters produced including:

TWS II, TWS II Bridge, DVE, DRVCS, LTLM, CHECK-6[®], TIM[™] 1500, ENVG and many others

- Aircraft Instrumentation:

General Aviation

Commercial

Military



Organization Chart

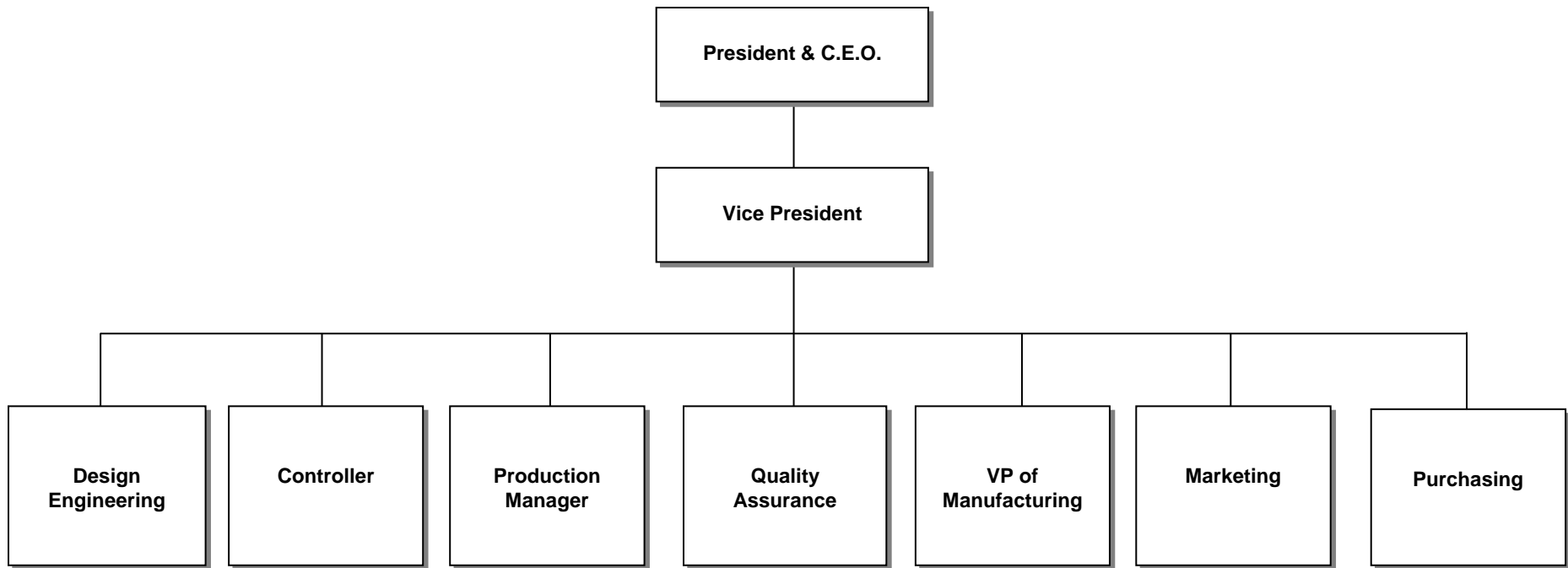



Facilities

- Building 1:
 - Administration
 - Marketing
 - Purchasing
 - Engineering
 - Machining / Materials Finishing
 - Assembly
 - Quality Assurance
- Building 2:
 - Machining / Materials Finishing
 - Engineering Lab





Expansion

- Plans for expansion:
 - We have plans to expand the size of building #1 which will provide a total of approximately 18,000 square feet





Manufacturing

- What is manufactured at Brandstrom vs. what is outsourced:
 - Brandstrom Instruments, Inc. is a vertically integrated manufacturing company
 - We outsource on a very limited basis
 - We purchase bobbins, coils, magnets, and some shutter blades
 - All other parts are manufactured at either of our two facilities in Ridgefield, CT
 - Our 14 CNC machines provides us with modern state of the art: capacity, parts tolerances, and repeatability





Manufacturing Equipment

<u>Qty</u>	<u>Model</u>	<u>Equipment</u>
2	Star SV 32	Machining Centers
2	Star SR 20R Type III	Machining Centers
6	Star SR 20J Type N	Machining Centers
2	MAIER MLK-32E	Machining Centers
2	MAIER MLK-125 Linear	Machining Centers
1	Miltronics VKM 4 CNC	Milling Machine
3	Bridgeport	Milling Machines
2	Hardinge HC	Lathe Machines
1	Datron EXV7 CNC	Milling Machine
3	Jones Lamson +Dorsey	Optical Comparators
1	Micro View Vertex 220	Measuring System
1	Micro View Sol	Measuring System
1	Lasonall Laser	Marking Machine
1	CROB 4V-18	Bandsaw
1	HYD-Mech P350	Cold Saw
2	Perkins Jr. 5 Ton	Punch Presses
1	Benchmaster 10 Ton	Punch Press
7	Twister LT-1BR	Speed Lathe
1	Harig 618 Ballway	Surface Grinder
Note:	Plus assorted support equipment	





Lab / Test Capabilities



- Vibration DC to 11,000 Hz, 26 g peak
- 1000 frames/sec video & flight times
- Magnetic flux and Inductance
- Image capture Microscope
- Torque vs. Angle
- Sound Level
- Custom Pulse Generator & Oscilloscope, Data acquisition Switch
- Environmental Chamber -73°C to 200°C Temperature and Humidity



Quality System

**Brandstrom Instruments is
AS9100D and ISO 9001:2015
Certified and Registered**

CERTIFICATE

Certificate Number: 131945.00

The Aerospace Quality Management System and implementation of:

Brandstrom Instruments, Inc.

With Central Functions At:
85 Ethan Allen Highway
Ridgefield, CT 06877
United States

The certification has been performed in accordance with the requirements of AS9104/1:2012, including its implementation, and meets the requirements of the standard:

AS9100D

(Based on and including ISO 9001:2015)

Scope:

Design, manufacture, and test of miniature rotary solenoids, shutters, and aircraft indicators, used in thermal and optical imaging and laser blocking.

Certification Structure: Single

Certificate Expiry: October 06, 2026
Certificate Issued: October 07, 2023
Certified Since: October 07, 2014

Dr. Cem O. Onus
Managing Director

DEKRA Certification, Inc.
1945 The Exchange SE #300
Atlanta, GA 30339 USA
(215) 997-4519
<https://www.dekra.us/en/audits/>

DEKRA Certification Inc. is an accredited Aerospace Registration Management Program Certification Body, under the ICOP scheme.





Quality Products

- Proven Customized Designs
 - No Springs
 - Long life bearing- no lubricants
 - Balanced moments of inertia
 - FOD - Contaminant free
 - Temperature, shock, and vibration tolerant
- Highest quality materials
- Precision machining in-house
- Excellent workmanship

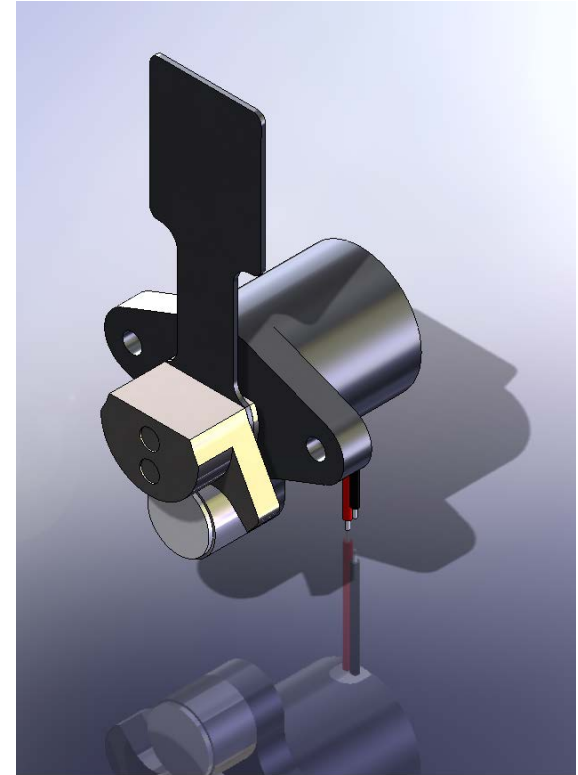

-Extreme Repeatability and Reliability-



Custom Product Development

Brandstrom Instruments Development Policy:

- Available for direct communication with you engineers.
- Provide custom designs per customer specifications
- Supply 3D models for fit check

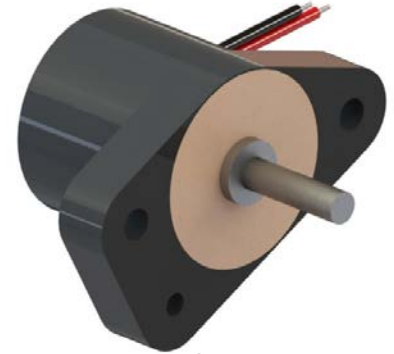

Brandstrom Instruments can provide Solenoids with customization of the following:

- Rotation Angle / Direction
- Shutter Attachment
- Finishes of Shutter/Solenoid
- Solenoid voltage
- Solenoid Holding Torque
- Solenoid Mounting
- Low-outgas versions
- Ability to manufacture solenoid/shutter assemblies that have reduced audio signatures for special applications.





COTS Rotary Solenoids

- COTS (Commercial Off The Shelf) line of both our 3/8" and 7/16" solenoids are available.
- These use the same time proven internal design/materials of our custom units.
- These units are meant to be mounted utilizing a pinch clamp on the thicker collar portion of the solenoid.
- They are offered in 3 different voltages, 5, 12 and 24 volts.
- Versions both Self-restoring and Bi-stable are offered.
- Rotation CW Self-restoring: 30°, 45°, 60°
- Rotation CW Bi-stable: 45°, 60°, 90°
- Less cost than custom design.
- Faster lead time than custom design.



COTS Rotary Solenoids Dimensional Data

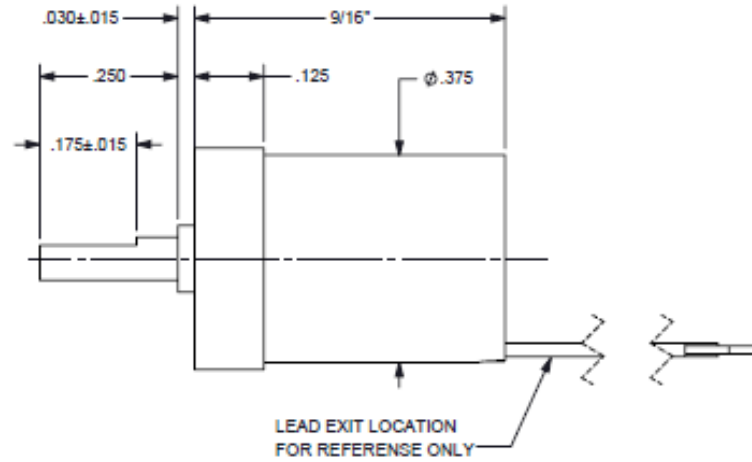
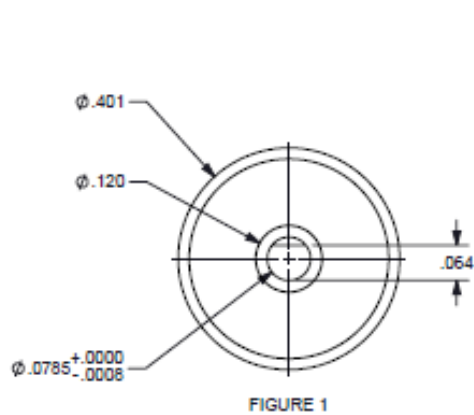

3/8"

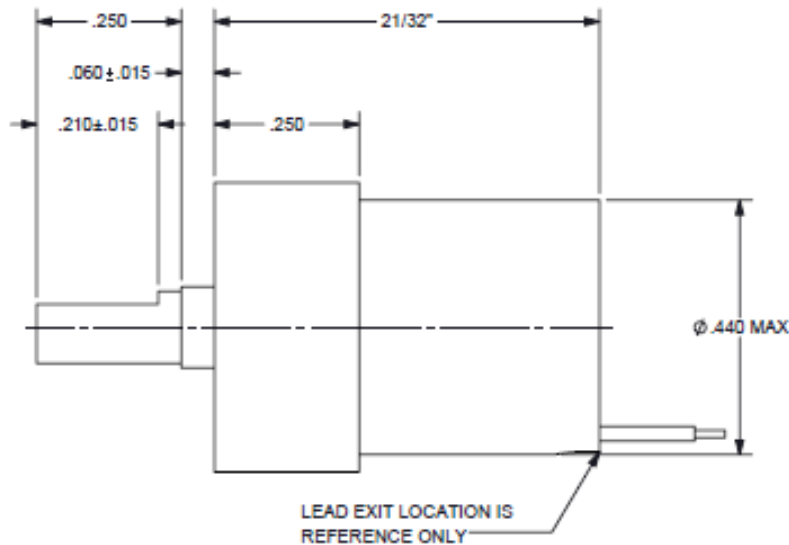
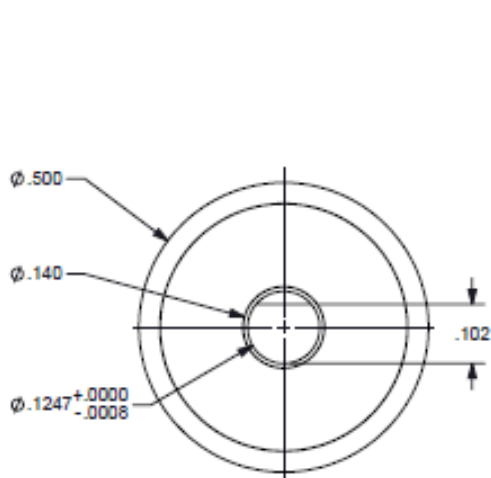
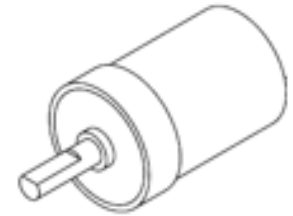

7/16"

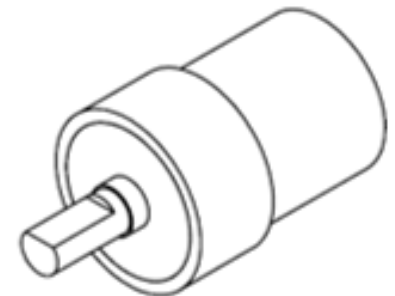



COTS Shutters

- We also offer COTS (Commercial Off The Shelf) Shutters for both our 3/8" and 7/16" solenoids.
- They are offered in either un-finished Aluminum or Black Anodize.
- -1 Series is Black Anodized per MIL-A-8625F, CASS II, TYPE II
- -2 Series is un-finished Aluminum
- Less cost than custom design.
- Faster lead time than custom design.



COTS Shutters Dimensional Data

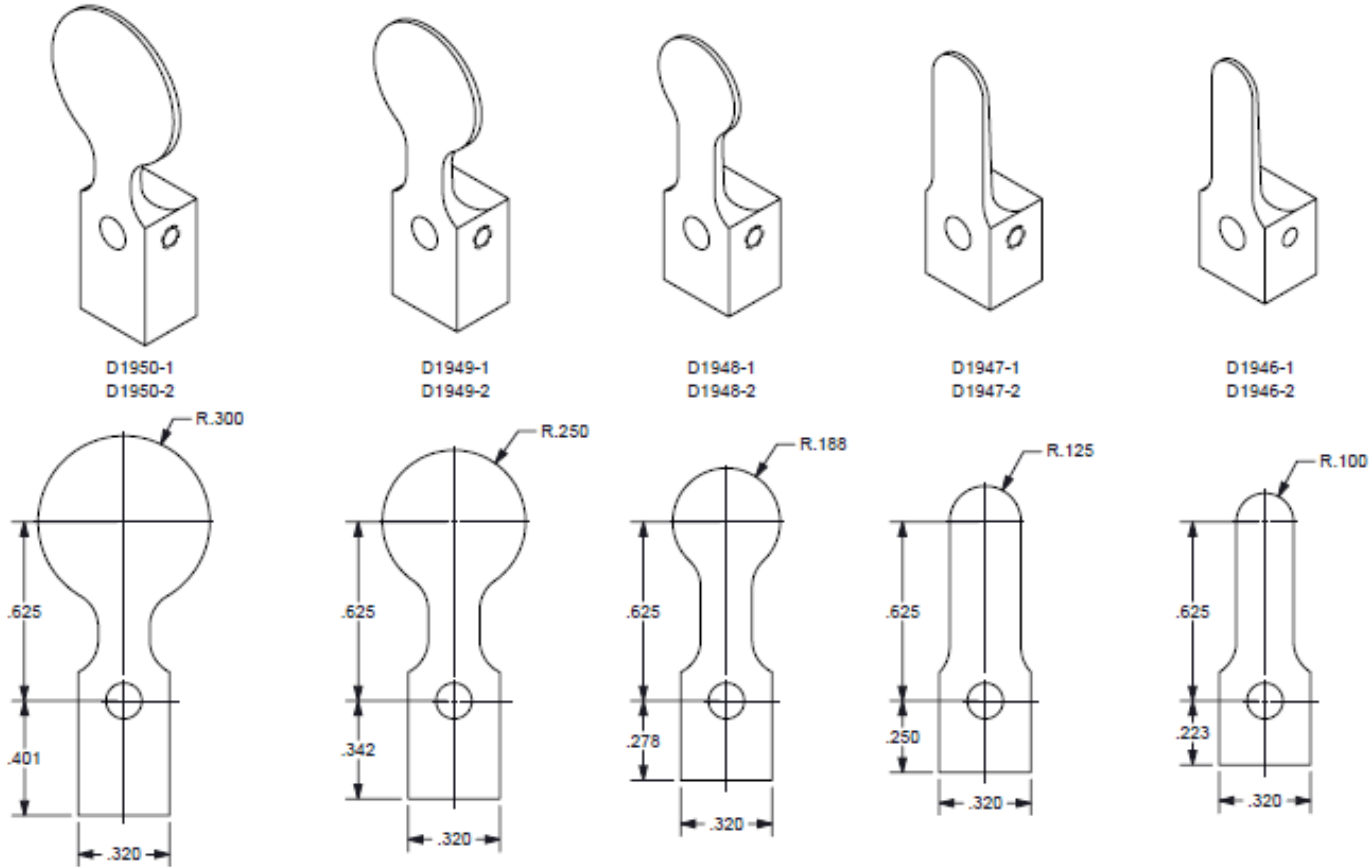



Thank You

**Brandstrom
Instruments**

Forward Thinking in Optical Shutter Technology

Rotary Solenoids, Shutters, and Indicators

Our Mission Statement

"Consistently meet or exceed our customer's expectations for product quality, reliability, performance, and delivery by providing products and services of the highest possible standards and integrity."



We thank you for putting your trust in Brandstrom.

-The Brandstrom Team-

www.brandstrominstruments.com (203) 544 - 9341

*Since
1972*